

Contents

Sprockets



- 120** uni SNB M2AT
uni Light EP

- 121** uni SSB
uni XLB

- 122** Two part sprockets for uni 800, uni 802, uni 805, uni 821, uni 821-PRR4, uni 821-PRR,
uni 810, uni 812, uni 815, uni Magnet type
uni 820, uni 831 and uni SSB

- 123** Two part sprockets for uni 879, uni 879 TAB, uni 879 Super Flex, uni 880,
uni 880 TAB-RT, uni 880 Super Flex, uni 879 TAB Safety,
uni 879 TAB Safety Finger, uni 880 Rib, uni 880 Rib-Flex and uni 879 TAB-R-G4
uni 881, uni 881 TAB, uni 8811 and uni 8811 TAB
uni 882, uni 882 TAB, uni 882 SC-TAB, uni 882 Rib-Flex,
uni 882 PRR-TAB4 and uni 882 PRR TAB

- 124** Sprockets for Snap-On chains

- 125** Idlers and Guide Rings

- 126** uni Retainer Rings

- 127** Disclaimer and Warnings

Material Properties • Steel

Austenitic Stainless Steel

SS304

Austenitic quality containing 18% chrome and 8% nickel.

Werkstoff no. 1.4301

AISI 304

$^{18}/_8$ CrNi steel is non-magnetic in the entire recommended temperature area. The austenitic quality has a very high degree of corrosion resistance in oxidizing surroundings. In connection with evaporation of chloride-containing fluids, being evaporated the $^{18}/_8$ CrNi steel is not recommended as stress corrosion can occur overtime.

Pin material for chains made of this austenitic stainless steel: $^{18}/_8$ CrNi steel, cold drawn to high hardness and strength.

Ferritic Stainless Steel

SS430

Ferritic quality containing 17.5% chrome.

Werkstoff no. 1.4016

AISI 430

The ferritic quality has a high wearability and is economical where demands for corrosion resistance are not very strong. The corrosion resistance of the ferritic quality is not as high as for the austenitic quality, but it does not have a tendency to stress corrode in a chloride environment.

Pin material for chains made of this ferritic stainless steel: $^{18}/_8$ CrNi steel, cold drawn to high hardness and strength.

Special Hardened Steel

S1045

AISI 1045

Special hardened steel with 0.45% carbon.

The carbon steel has a hardness of 36-42 HRC.

The products are through hardened.

Pin material for chains made of this special hardened steel: $^{18}/_8$ CrNi steel, cold drawn to high hardness and strength.

Note: Other grades can be supplied upon request. Steel chains with ground top surface are available. Please contact uni-chains.

	Austenitic stainless steel SS304	Ferritic stainless steel SS430	Special hardened steel S1045
Recommended temperature area	-70 to +430°C -94 to +806°F	-70 to +430°C -94 to +806°F	-70 to +430°C -94 to +806°F
Magnetic properties	Non-magnetic*	Magnetic	Magnetic
Chain supplied in the material	SS805 SS815 SS881/SS881 TAB SS881 SFL SS8811 SFL SS8811/SS8811 TAB	SS802 SS812 SS881/SS881 TAB SS Magnet type SS881 SFL SS8811 SFL	S800 S810 S881/S881 TAB S Magnet type S881 SFL S8811 SFL

Please note, that the temperature may have an effect on the mechanical properties of the chains.

* Remanent magnetism may occur in the chains.

Material Properties • Plastic Standard Grades

Polyoxymethylen - POM

Colour options: A row of 13 small square color swatches: blue, grey, red, light grey, green, black, white, orange, purple, tan, white, and yellow.

Other custom-made colours are available on request.

POM is a thermoplastic material with very good mechanical and thermal properties. The material can also be characterized by great strength, elasticity and dimensional stability. POM is resistant to a wide selection of chemicals. POM has good qualities for slide material, low coefficient of friction and a good resistance to wear.

Recommended temperature area: -40 to +90°C (-40 to +194°F).

Standard material for our plastic chains is POM which is made in 3 different grades.

POM-D

POM polymers with self-lubricating components.

POM-I

POM polymers with self-lubricating components and improved impact resistance.

POM-LF

POM polymers with improved self-lubricating components.

POM-SLF

POM polymers with self-lubricating additives to obtain the lowest possible friction resistance.

Polypropylene - PP

Colour options: A row of 11 small square color swatches: blue, red, green, light grey, black, white, orange, purple, tan, white, and yellow.

Other custom-made colours are available on request.

Polypropylene is a thermoplastic material with very good chemical resistance properties. PP is an economical material for applications with high temperatures.



Recommended temperature area: +1 to +104°C (+33 to +219°F).

Standard pin material for plastic chains is $18/8$ CrNi steel, but most types can be supplied with plastic pins too.

Note: uni-chains also produces plastic chains in other materials for use under special conditions, please see page 15.

Material Properties • Plastic Special Grades

Glass Reinforced Polyester - GR

Colour options:  

Glass reinforced polyester is a material with an extremely high resistance to wear and heat.

Glass Reinforced Polypropylene - AR

Colour options:   



AR is an acid resistant material which is used where very high chemical resistance is required. The limited mechanical strength of polypropylene is considerably improved by the glass fiber reinforcement.

Antistatic Material - AS

Colour options: 

Electrically conductive acetal is used where the build-up of static electricity must be avoided e.g. in the aerosol and electronics industry.

Polycarbonate - PC

Colour options:  

Polycarbonate is characterized by being extremely impact resistant, even at low temperatures.

Flame Retardant Polyamide - FR

Colour options: 

Flame retardant polyamide is a fire restricting material used in surroundings with the danger of being ignited the chain.

Polyvinylidenfluoride - PVDF

Colour options: 



Polyvinylidenfluoride is characterized by a specially high chemical resistance. Furthermore PVDF has high wear resistance and good friction properties.

Polyamide - PA6

Colour options:      

Polyamide PA6 is a thermoplastic material. The combination of mechanical properties and chemical resistance makes this material suitable for many situations. Polyamide has a high resistance of dynamic loads and a high wear resistance.

Polyamide - PA6.6

Colour options:    

Polyamide PA6.6 is a thermoplastic material with many fine properties. The material has a high resistance to wear and high strength and great stiffness. Furthermore polyamide has a large temperature area.

Note: Max permissible working load is reduced by 50% when using AS and AR. For all other special materials, please contact uni-chains for permissible working load.

Please contact uni-chains if materials other than those listed above are needed.

	Temperature range	
	°C	°F
Glass reinforced polyester - GR	-40 to +125°C*	-40 to +257°F*
Glass reinforced polypropylene - AR	+1 to +80°C	+33 to +176°F
Antistatic material - AS	-40 to + 90°C	-40 to +194°F
Polycarbonate - PC	-20 to +130°C	-4 to +266°F
Flame Retardant Polyamide - FR	+1 to +104°C	+33 to +219°F
Polyvinylidenfluoride - PVDF	-40 to +100°C	-40 to +212°F
Polyamide - PA6	-40 to +120°C	-40 to +248°F
Polyamide - PA6.6	-40 to +140°C	-40 to +284°F

* Max temperature in water +60°C (+140°F).

Please, note that the temperature may have an effect on the mechanical properties of the chains.



The main application is for conveying glass bottles. uni 812 e.g. is suitable for soft drinks breweries, bottling plants and uni 815 for the wine industry. Chain lubrication is recommended. The chains can be supplied with a ground surface for widths up to 114.3 mm (4.50 in.): Type SSX. These chains are mainly used for inline feeders and pressureless combiners. The K325 chain in all materials with the width 82.6 mm (3.25 in.) is available with a larger plate distance (PD). This chain has a smaller backflex radius. Designation for this version is SSR815 and SSR812 respectively.

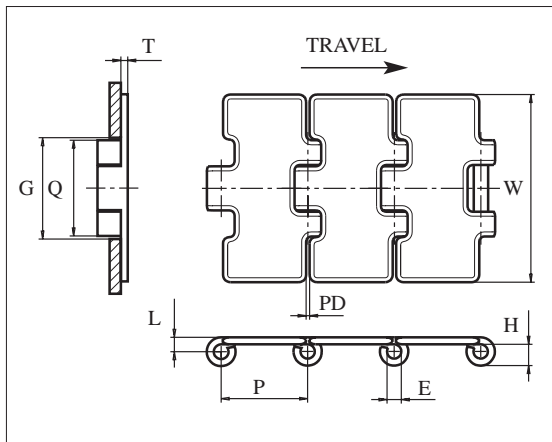

	mm	in.
E	6.4	0.25
G	44.5	1.75
H	9.5	0.37
L	6.4	0.25
P	38.1	1.50
Q	42.1	1.66
T	3.1	0.12
PD*	1.8	0.07

* For uni SSR-K325 PD is 2.8 mm (0.11 in.)

Items with **bolded** uni reference numbers are standard.
Items with uni reference numbers in *italic* are available on a made-to-order basis.

uni 810/812/815 Slat Top Chains • Steel

	Straight running
	38.1 mm (1.50 in.)
	See page 13
	SS304 See page 13
	150 mm (5.9 in.) SSR812/SSR815: 75 mm (3 in.)
	See page 111
	See page 122
	See page 125
	See page 108
	3.048 m = 10 ft No. of links/box: 80
	S1045 4000 N (899 lbf) SS430 2250 N (506 lbf) SS304 2250 N (506 lbf)





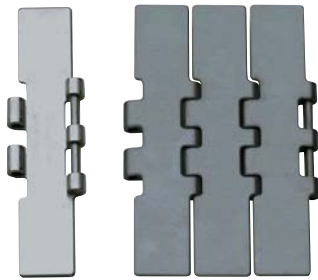





	uni reference no.			width W		weight	
	SS304	SS430	S1045	mm	in.	kg/m	lb/ft
uni 810/812/815-K225	<i>12SS815K225</i>	12SS812K225	12S810K225	57.2	2.25	2.2	1.48
uni 810/812/815-K250	<i>12SS815K250</i>	12SS812K250	<i>12S810K250</i>	63.5	2.50	2.3	1.55
uni 810/812/815-K263	<i>12SS815K263</i>	<i>12SS812K263</i>	<i>12S810K263</i>	66.7	2.63	2.4	1.61
uni 810/812/815-K275	<i>12SS815K275</i>	<i>12SS812K275</i>	<i>12S810K275</i>	69.9	2.75	2.4	1.61
uni 810/812/815-K300	<i>12SS815K300</i>	<i>12SS812K300</i>	<i>12S810K300</i>	76.2	3.00	2.6	1.75
uni 810/812/815-K325	12SS815K325	12SS812K325	12S810K325	82.6	3.25	2.6	1.75
uni 810/812/815-K350	<i>12SS810K350</i>	<i>12SS812K350</i>	<i>12S810K350</i>	88.9	3.50	2.7	1.81
uni 810/812/815-K400	12SS815K400	12SS812K400	<i>12S810K400*</i>	101.6	4.00	3.2	2.15
uni 810/812/815-K450	12SS815K450	12SS812K450	12S810K450	114.3	4.50	3.5	2.35
uni 810/812/815-K600	12SS815K600	12SS812K600	12S810K600	152.4	6.00	4.4	2.96
uni 810/812/815-K750	12SS815K750	12SS812K750	12S810K750	190.5	7.00	5.3	3.56
uni R812/R815-K325	<i>12SSR815K325</i>	<i>12SSR812K325</i>		82.6	3.25	2.6	1.75

* Standard in US.



The main application is for conveying glass bottles.
 uni 802 e.g. is suitable for soft drinks, bottling plants, breweries and uni 805 for the wine industry.
 Chain lubrication is recommended.
 The chain has a relatively high tensile strength which can be utilized for long conveyors or for large and heavy items.

uni 800/802/805 Slat Top Chains • Steel

-  Straight running
-  38.1 mm (1.50 in.)
-  See page 13
-  **SS304** See page 13
-  150 mm (5.9 in.)
-  See page 111
-  See page 122
-  See page 108
-  3.048 m = 10 ft
No. of links/box: 80
- 

S1045	6000 N (1349 lbf)
SS430	3500 N (787 lbf)
SS304	3500 N (787 lbf)

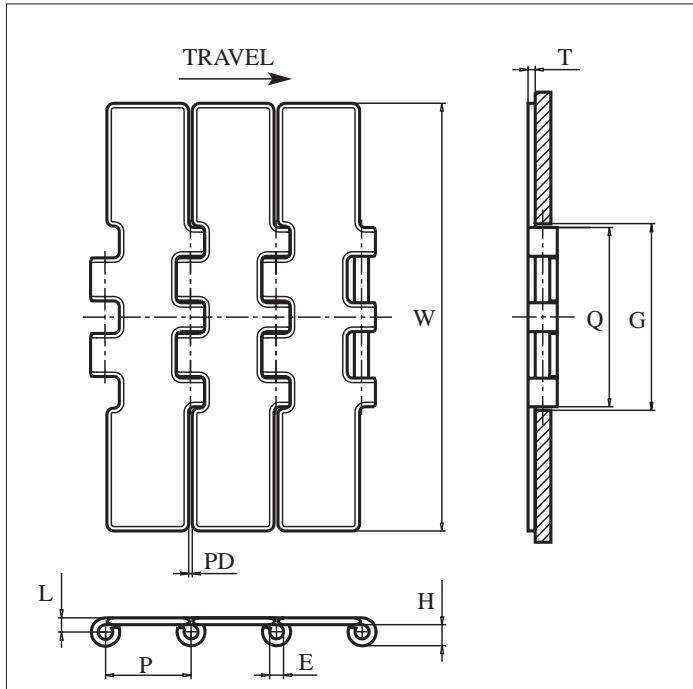

	mm	in.		mm	in.
E	6.4	0.25	P	38.1	1.50
G	82.5	1.75	Q	79.4	3.13
H	9.5	0.37	T	3.1	0.12
L	6.4	0.25	PD	1.8	0.07

Items with **bolded** uni reference numbers are standard.
 Items with uni reference numbers in *italic* are available on a made-to-order basis.

	uni reference no.			width W		weight	
	SS304	SS430	S1045	mm	in.	kg/m	lb/ft
uni 800/802/805-K750	<i>10SS805K750*</i>	10SS802K750	<i>10S800K750*</i>	190.5	7.50	5.8	3.90

* Standard in US.



uni SS881 (430) is suitable for soft drinks, bottling plants, breweries and uni SS2881 (304) for the wine industry.

Chain lubrication is recommended. The chains can be supplied with a ground surface for widths up to 114.3 mm (4.50 in.): Type SSX. The chain is supplied with bevels to retain the chain in the curved conveyor sections.

Please note, the R-type has a minimum turn radius of 200 mm (7.87 in.). This space-saving chain is often used with small diameter turn discs with ball bearings.

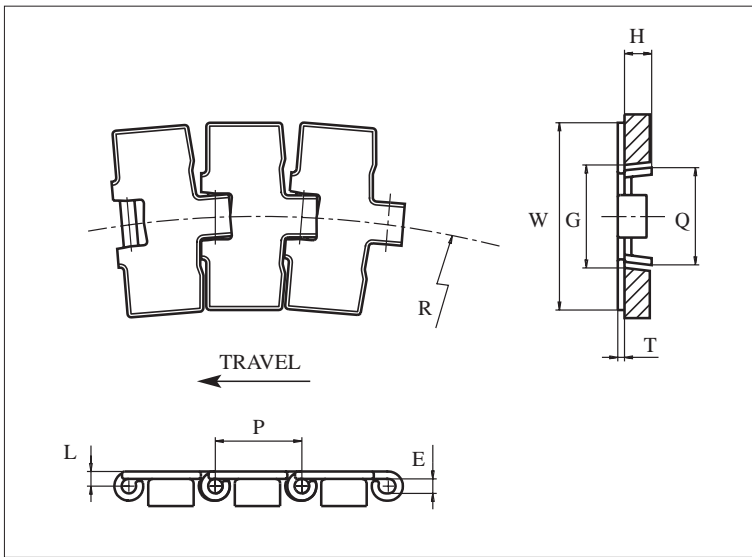

	mm	in.		mm	in.
E	6.4	0.25	L	6.4	0.25
G (curve)	41.3	1.63	P	38.1	1.50
G (straight)	46.6	1.83	Q	43.0	1.69
H	11.9	0.47	T	3.1	0.12

Items with **bolded** uni reference numbers are standard.
Items with uni reference numbers in *italic* are available on a made-to-order basis.

	uni reference no.			width W		weight		min. radius R	
	SS304	SS430	S1045	mm	in.	kg/m	lb/ft	mm	in.
uni 881-K325R	<i>13SS2881K325R</i>	<i>13SS881K325R</i>	<i>13S881K325R</i>	82.6	3.25	3.0	2.02	200	7.87
uni 881-K325	13SS2881K325	13SS881K325	<i>13S881K325</i>	82.6	3.25	3.0	2.02	457	17.99
uni 881-K450	13SS2881K450	13SS881K450	<i>13S881K450</i>	114.3	4.50	3.7	2.49	610	24.02
uni 881-K750	13SS2881K750	<i>13SS881K750</i>	<i>13S881K750</i>	190.5	7.50	5.5	3.70	610	24.02

uni 881 Slat Top Chains • Steel

- Side flexing
- 38.1 mm (1.50 in.)
- See page 13
- SS304** See page 13
- 75 mm (3 in.)
- See page 112
- See page 123
- See page 125
- See curve catalogue
- See curve catalogue
- See page 108
- 3.048 m = 10 ft
No. of links/box: 80
- SS430** 2250 N (506 lbf)
SS304 2250 N (506 lbf)
S1045 4000 N (899 lbf)



uni SS881 TAB (430) is suitable for soft drinks breweries, bottling plants and uni SS2881 TAB (304) for the wine industry. Chain lubrication is recommended.

uni S881 TAB (S1045) is used in automotive and material handling industries.

The chains can be supplied with ground surface for widths up to 114.3 mm (4.50 in.): Type SSX. The chain is supplied with welded tabs to retain the chain in the curved conveyor sections. Please note, the R-type has a minimum turn radius of 200 mm (7.87 in.). This space-saving chain is often used with small diameter turn discs with ball bearings.

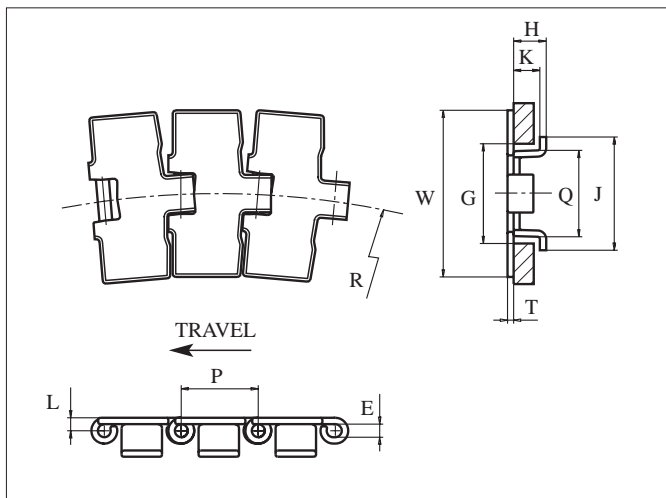

	mm	in.		mm	in.
E	6.4	0.25	L	6.4	0.25
G	44.5	1.75	P	38.1	1.50
H	16.3	0.64	Q	43.0	1.69
J	56.2	2.21	T	3.1	0.12
K	12.7	0.50	-	-	-

Items with **bolded** uni reference numbers are standard.
 Items with uni reference numbers in *italic* are available on a made-to-order basis.

	uni reference no.			width W		weight		min. radius R	
	SS304	SS430	S1045	mm	in.	kg/m	lb/ft	mm	in.
uni 881 TAB-K325R	<i>13SS2881TK325R</i>	13SS881TK325R	<i>13S881TK325R</i>	82.6	3.25	3.2	2.15	200	7.87
uni 881 TAB-K325	13SS2881TK325	13SS881TK325	13S881TK325	82.6	3.25	3.2	2.15	457	17.99
uni 881 TAB-K450	13SS2881TK450	13SS881TK450	13S881TK450	114.3	4.50	3.9	2.62	610	24.02
uni 881 TAB-K750	13SS2881TK750	13SS881TK750	13S881TK750	190.5	7.50	5.7	3.83	610	24.02

uni 881 TAB Slat Top Chains • Steel

- Side flexing
- 38.1 mm (1.50 in.)
- See page 13
- SS304** See page 13
- 75 mm (3 in.)
- See page 112
- See page 123
- See curve catalogue
- See curve catalogue
- See curve catalogue
- See page 108
- 3.048 m = 10 ft
No. of links/box: 80
- SS430** 2250 N (506 lbf)
SS304 2250 N (506 lbf)
S1045 4000 N (899 lbf)



The main application is for conveying glass bottles. uni 881 Super Flex chain has special designed angled inverted tabs on the underside. The SFL shoe ensures that the chain is always held totally flat against the wearstrips in curves. Its design also reduces vibrations. Therefore the problems normally associated with conveying unstable bottles and containers are minimized. Super Flex chains can be removed from the carry wearstrips (straights and curves) without the use of tools. Please note the R-type has a minimum turn radius of 200 mm (7.87 in.). This space-saving chain is often used with small diameter turn discs with ball bearings.

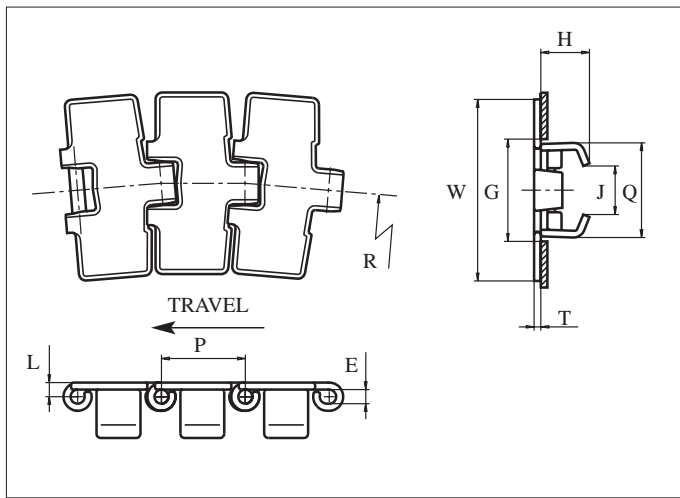

	mm	in.		mm	in.
E	6.4	0.25	L	6.4	0.25
G	46.5	1.83	P	38.1	1.50
H	22.0	0.87	Q	42.7	1.68
J	24.5	0.96	T	3.1	0.12

Items with **bolded** uni reference numbers are standard. Items with uni reference numbers in *italic* are available on a made-to-order basis.

	uni reference no.			width W		weight		min. radius R	
	SS304	SS430	S1045	mm	in.	kg/m	lb/ft	mm	in.
uni 881 SFL-K325R	<i>13SS2SFLK325R</i>	<i>13SSSFLK325R</i>	<i>13SSFLK325R</i>	82.6	3.25	3.0	2.02	200	7.87
uni 881 SFL-K325	<i>13SS2SFLK325</i>	<i>13SSSFLK325</i>	<i>13SSFLK325</i>	82.6	3.25	3.0	2.02	457	17.99
uni 881 SFL-K450	<i>13SS2SFLK450</i>	<i>13SSSFLK450</i>	<i>13SSFLK450</i>	114.3	4.50	3.7	2.49	610	24.02
uni 881 SFL-K750	<i>13SS2SFLK750</i>	<i>13SSSFLK750</i>	<i>13SSFLK750</i>	190.5	7.50	5.5	3.70	610	24.02

uni 881 Super Flex Slat Top Chains • Steel

- Side flexing
- 38.1 mm (1.50 in.)
- See page 13
- SS304** See page 13
- 75 mm (3 in.)
- See page 112
- See page 125
- See curve catalogue
- See curve catalogue
- See curve catalogue
- 3.048 m = 10 ft
No. of links/box: 80
- SS430** 2250 N (506 lbf)
SS304 2250 N (506 lbf)
S1045 4000 N (899 lbf)



The main application is for conveying glass bottles.

The chain is retained in the curved conveyor sections by magnets built into the curves. The advantage of this is that the chain can easily be taken off these sections for cleaning, replacement of wearstrips etc.

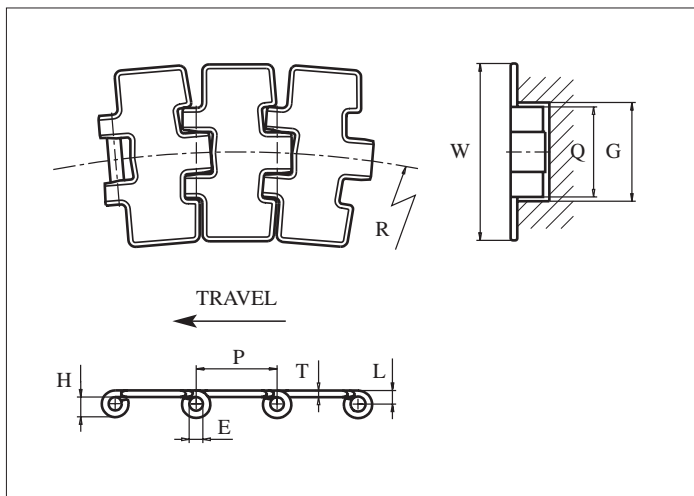











	mm	in.		mm	in.
E	6.4	0.25	P	38.1	1.50
G	44.0	1.73	Q	42.0	1.65
H	9.6	0.38	T	3.1	0.12
L	6.4	0.25	-	-	-

Items with **bolded** uni reference numbers are standard.
 Items with uni reference numbers in *italic* are available on a made-to-order basis.

	uni reference no.		width W		weight		min. radius R	
	SS430	S1045	mm	in.	kg/m	lb/ft	mm	in.
uni Magnet type-K325	13SSMAGNETK325	<i>13SMAGNETK325</i>	82.6	3.25	2.4	1.61	440	17.32
uni Magnet type-K450	13SSMAGNETK450	<i>13SMAGNETK450</i>	114.3	4.50	3.1	2.08	457	17.99
uni Magnet type-K750	13SSMAGNETK750	<i>13SMAGNETK750</i>	190.5	7.50	4.5	3.02	457	17.99

uni Magnet type Slat Top Chains • Steel

-  Side flexing
-  38.1 mm (1.50 in.)
-  See page 13
-  **SS304** See page 13
-  75 mm (3 in.)
-  See page 111
-  See page 122
-  See page 125
-  3.048 m = 10 ft
No. of links/box: 80
-  **SS430** 2250 N (506 lbf)
S1045 4000 N (899 lbf)